

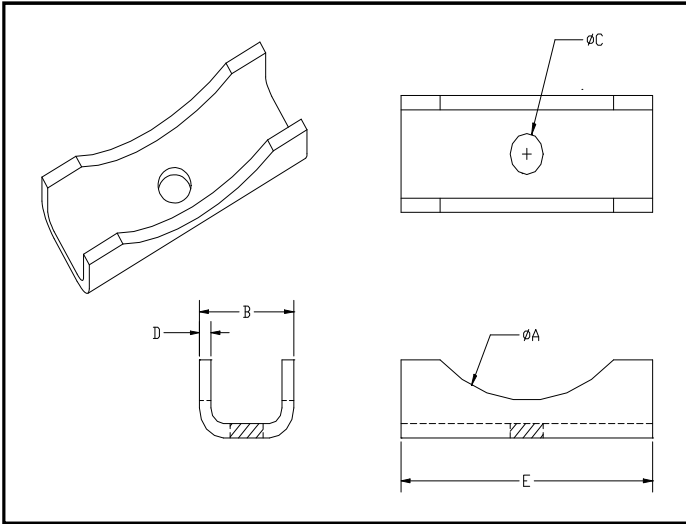

SPRING SEAT PRODUCTS AS OF 12/1/2008

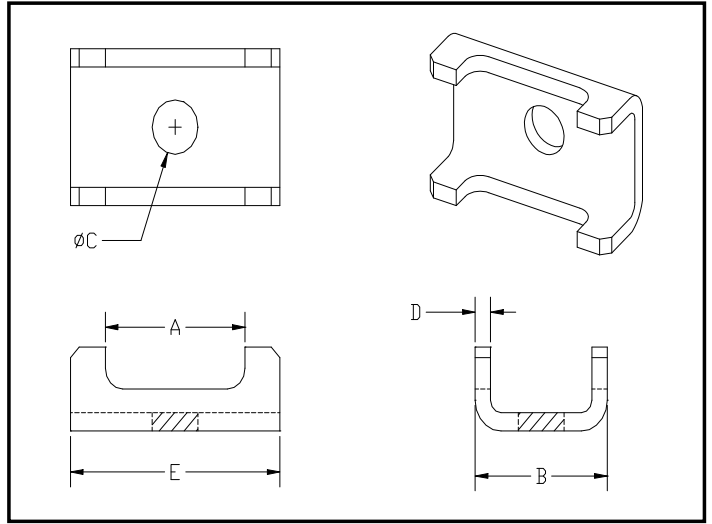

TYPE 1



TYPE 2

PART #	TYPE	A	B	C	D	E
PS-ST1	1	1.75"	1.85"	0.670"	0.220"	2.25"
PS-ST2	1	2.375"	1.85"	0.670"	0.220"	4"
PS-ST3	1	3"	1.85"	0.670"	0.220"	4"
PS-ST4	2	2"	1.85"	0.670"	0.220"	3"